

Problem Solving with Actuators



Three ways to enhance your cutting applications



Non-rotating cylinder solves cutting problem for paper bag manufacturer.

Non-rotating cylinder solves cutting problem for paper bag manufacturer

Problem: A paper bag manufacturer was experiencing rotation tolerance problems during their bag slicing process prior to lamination. Non-rotation is critical in this application because if a blade turns while cutting it can cause a catastrophic failure.

Solution: A custom-designed Bimba Non-rotating Original Line cylinder was the answer to their rotation problems. It features a single acting design with a solenoid valve attached directly to the rear head. A stainless steel razor provides the precision slicing needed for this application. (See above diagram.)

Ultran® performs reliably and survives caustic washdowns

Problem: As part of its food bagging operations, this company cuts 3" x 4" moisture-absorbing pads. They needed a reliable actuator, and one that could withstand a corrosive washdown environment.

Solution: Bimba's Ultran rodless cylinder, which cuts the material with a rotary blade. Since there is no rod extension, the Ultran is perfect for cutting between two fixed points. And, because Ultran is completely sealed and made of stainless steel and anodized aluminum parts, the cylinder can tolerate caustic washdowns.

Pneu-Turn® cuts tough materials and eliminates costly shock absorbers

Problem: This company already used a rotary actuator to cut plastic extrusions at a very fast cycle rate. However, each actuator required expensive shock absorbers to slow the knife at the end of each cycle.

Solution: The company replaced these components with Bimba Pneu-Turn rotary actuators with adjustable cushions. The cushions sufficiently slow the knife and eliminate the need for costly shock absorbers.

Three answers for improving your lifting and lowering applications

Original Line cylinders meet speed and accuracy requirements for bottle-filling application

Problem: Lowering speed and accuracy were critical in this bottle-filling application. And, frequent caustic washdowns made the use of corrosion-resistant components a necessity.

Solution: Bimba Original Line cylinders were chosen for their reliable and smooth performance. The cylinders lower the filling nozzles into position, triggering the flow of liquid. With 12 filling heads, the system fills up to 240 100ml bottles per minute. The precision rate for small bottles is 0.5 percent. The stainless steel bodies and specially designed nickel-plated end caps protect the cylinders during caustic washdowns.

Long-lasting Flat-1® cylinders increase semiconductor manufacturer's productivity

Problem: A semiconductor manufacturer was using a space-saving cylinder for lifting wafer transfer hardware and was experiencing high failure rates with their aluminum body cylinder, which greatly impacted their productivity.

Solution: A specially designed space-saving Flat-1 cylinder was installed to provide the lifting motion. With its durable stainless steel body construction, the Flat-1 cylinder not only proved to be a long-lasting performer, it also offered the smooth motion needed for the precise lifting of the wafer transfer hardware.

TRD Air/Oil cylinder solves a machine builder's lifting problems

Problem: A machine builder was searching for a way to lock two cylinders together as they lifted a 14' machine frame. Key to this request was that the cylinders also operate in unison.

Solution: The answer to this engineering challenge turned out to be Bimba's TRD Air/Oil tandem cylinder. The cylinders were designed with a criss-crossing oil flow to allow the cylinders to move as one unit. Special tubing and piston seals were also used to eliminate leakage. (See below diagram.)

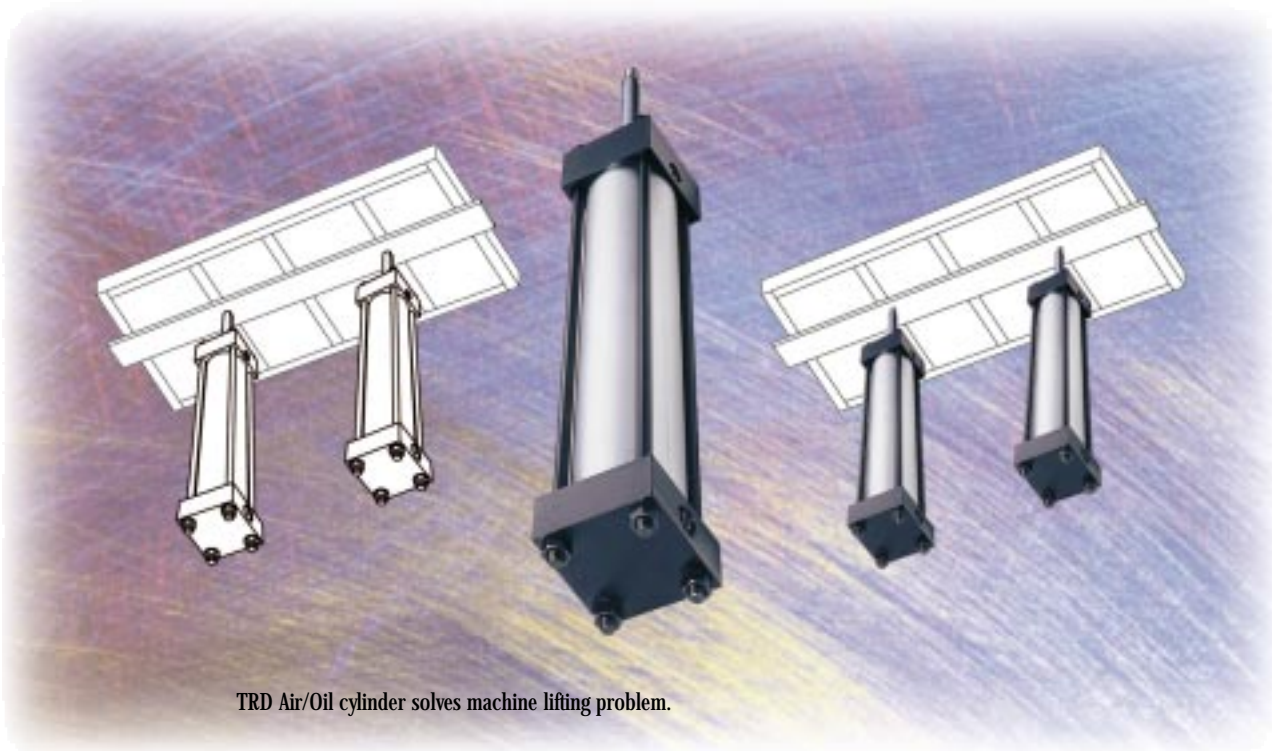

TRD Air/Oil cylinder solves machine lifting problem.

Three solutions to your pushing and transferring problems

Compact Flat-1 cylinders save space and meet force requirements

Problem: An OEM manufacturer used compact cylinders to push locating pins through case-hardened bushings into stamping dies once they were properly positioned on the die-changing equipment. The die is then either transferred onto a press or to storage. The company wanted to use even smaller cylinders but not compromise force.

Solution: Bimba's Flat-1 cylinders were specified because of their compactness. The Flat-1 cylinders also saved more space than another compact cylinder brand.

Ultran cylinder eliminates expensive seal and band replacements

Problem: After sheet metal is cut into proper lengths, the strips fall down a ramp into a trough. Once several metal strips are collected in the trough, a cylinder drives a ram through the trough and pushes the metal strips into a larger bin. The metal stamping operation frequently contaminated the 132" band cylinder. In fact, the cable and seal kits had to be replaced once every two to three weeks.

Solution: Bimba custom designed a 132" Ultran rodless cylinder for this pushing application. Ultran's sealed design eliminates the hassle and expense of replacing seals and bands. Plus, wipers on the Ultran prevent the metal stamping debris from interfering with the smooth operation of the cylinder.

Ultran cylinder helps eliminate costly maintenance and quality problems

Problem: A major manufacturer of printed circuit boards found their maintenance downtime and reject rates soaring due to the inaccurate transfer of the boards from one manufacturing process to another. Transferring a circuit board requires extremely smooth movement to prevent costly component damage and production interruptions.

Solution: To help eliminate these problems, the manufacturer chose Bimba's Ultran rodless cylinder that features a magnetically coupled design for smooth, consistent actuation; a new lubrication; and an improved bearing configuration for longer life. (See below diagram.)

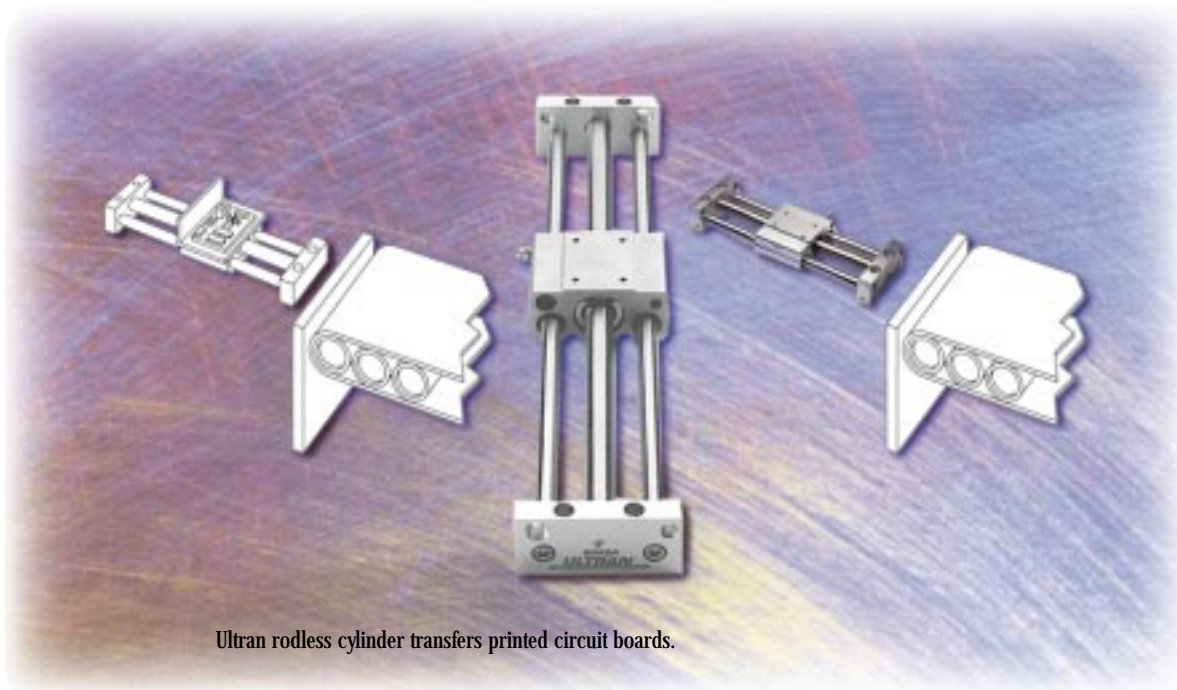

Ultran rodless cylinder transfers printed circuit boards.

Three ideas for your holding and positioning problems



FO2 cylinders cost-effectively flatten pizza crusts.

Pizza manufacturer reduces operating costs with FO2 cylinders

Problem: A mass production pizza manufacturer was looking for a cylinder with enough force to flatten 16" crusts while only using 25psi of air pressure.

Solution: The answer turned out to be Bimba's multiple power, stainless steel body FO2 cylinder. Not only did the cylinder provide two times the force of a single cylinder to effectively flatten these larger crusts, it also drastically cut air consumption along with minimizing setup time. (See above diagram.)

Original Line cylinders solve positioning problem in computer-controlled system

Problem: This company developed a cost-effective system for repairing printed circuit boards. Part of the process involved positioning the repair module over a printed circuit board. It was too expensive and time-consuming to develop a special part for this operation.

Solution: Two Bimba Original Line single acting cylinders with 2" of rod extension provided exact positioning of the repair module over the damaged circuit board. The cylinders are pivot mounted, with the rod end attached to the repair module. Use of the Original Line cylinders proved to be less expensive than designing a special mechanical device.

Original Line cylinders act as a gate to hold product; withstand caustic washdowns

Problem: This application is common in the bottle-filling industry. Bottles need to be partitioned off in a holding area until they are ready to be filled. Not only must the operation be reliable, but cylinders must be able to withstand caustic washdowns.

Solution: By installing two Bimba Original Line cylinders perpendicular to the bottles, a gate is created, allowing only the correct number of bottles to enter the filling area. The stainless steel body and specially designed nickel-plated end caps protect the cylinders during caustic washdowns.

Actuators can be used in a variety of indexing and sorting applications

Sorting application requires exceptionally fast actuation

Problem: Sorting requires the keen eye of a photo sensor and quick actuation. Sensors detect acceptable and unacceptable produce based on color. This agricultural firm needed a hardworking, fast acting cylinder to sort the good vegetables from the bad. In addition, the cylinder had to withstand acidic vegetable fluids.

Solution: Bimba's Original Line stainless steel body cylinders were installed. Because of the cylinder's special design, it was able to complete a cycle in 17 milliseconds. Adding to the long life of the cylinders were the bushing and bumper made of special materials.

Pneu-Turn reduces downtime in indexing application; improves productivity

Problem: This manufacturer's mechanical design indexed 180° every six to seven seconds. However, stress caused a 50 percent machine downtime rate. The system was upgraded to include cylinders, but downtime was still a problem.

Solution: The existing cylinders were replaced with Bimba's Pneu-Turn rotary actuators. Downtime was eliminated and machine setup time reduced. Plus, thanks to the smooth, controlled motion of Pneu-Turn, the machine's speed was increased by seven percent, improving production output. (See below diagram.)

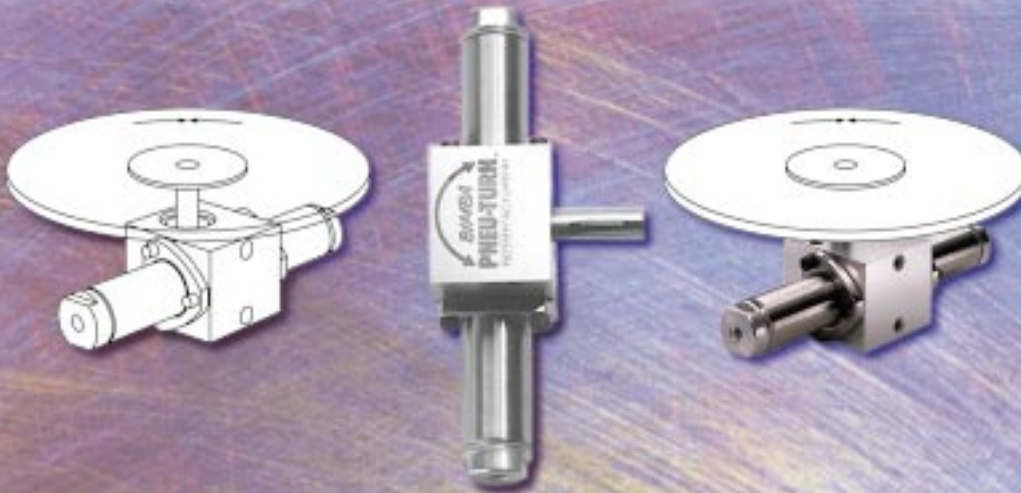

Pneu-Turn rotary actuator reduces downtime and improves productivity in indexing application.

Actuators can also be used to solve an application problem which requires a combination of motions



Original Line cylinder precisely controls shutter speed.

Original Line cylinder opens and closes shutter in medical test equipment

Problem: A medical testing equipment manufacturer was using an electric solenoid to open and close a shutter. Speed control was critical since the shutter was either blocking or allowing infrared light to pass through a test sample.

Solution: Bimba supplied a specially designed Original Line cylinder that allowed the manufacturer to precisely control the speed of the shutter's opening and closing. (See above diagram.)

Flat-1 cylinders solve tight space requirements while performing multiple functions

Problem: This manufacturer designed a robotic work cell automating an entire electronic assembly process, including trimming, forming, pre-heating, cleaning, inspection and assembly. The compact design of the automation system required small cylinders for a variety of motions: stopping, clamping, lifting and turning.

Solution: Bimba's Flat-1 cylinders are used extensively in this robotic system. The manufacturer liked the versatility and compact design of the Flat-1 cylinders.

Flat-1 cylinders move, load and unload product...all underwater

Problem: This application involved several complications. The cylinders needed to load product into a nest, move the nest into a tank for leakage testing and then unload the product. The cylinders had to not only perform a variety of tasks...but operate while submerged in water.

Solution: Bimba Flat-1 cylinders were custom designed with lip rod seals to seal internally and externally, and stainless steel fasteners for water service. The Flat-1 design was perfect for the compact mounting.

Actuators can improve precision in your pick and place application

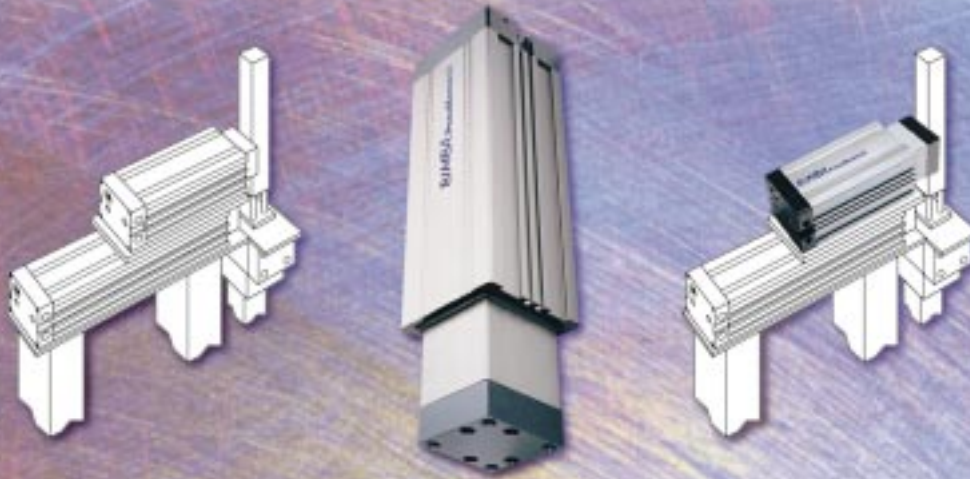

PneuMoment actuator effectively places auto parts into a fixture.

PneuMoment™ actuator reduces cycle time in robotic pick and place application

Problem: An automobile manufacturer needed a cylinder with both high side and moment load carrying capabilities for placing auto parts into a fixture.

Solution: The Bimba PneuMoment pneumatic actuator proved to be just the solution because it features high side and moment load carrying capabilities. It was used in conjunction with a robot and, as a result, the robot's cycle time has been significantly reduced. (See above diagram.)

Multi-axis configuration helps increase productivity

Problem: A conveyor manufacturer wanted to check various dimensions on a part as it moved along a conveyor without interrupting the flow and thereby increasing productivity.

Solution: The manufacturer chose a Bimba Linear Thruster and Pneu-Turn rotary actuator with a Transition Plate, along with a Position Feedback Cylinder. With this configuration, the manufacturer was able to pick the part off the conveyor, measure it and then place it back on the conveyor — in just eight seconds.

Your Stocking Bimba Distributor is:

For technical assistance,
call 1-800-44-BIMBA
(1-800-442-4622)



Bimba Manufacturing Company
Monee, Illinois 60449-0068
Phone: 708-534-8544
FAX: 708-534-5767

www.bimba.com

·ISO 9001·
CERTIFIED