

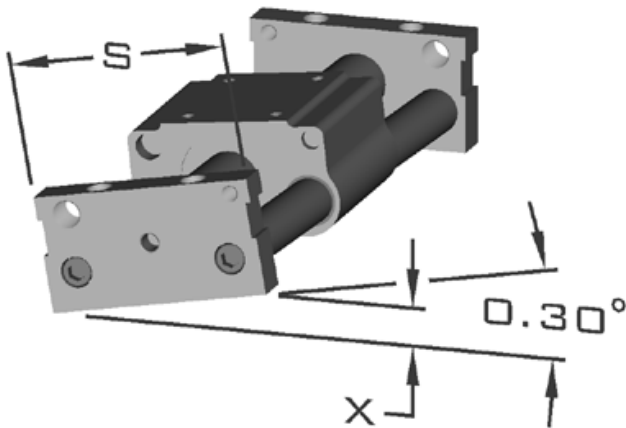

Ultran® Slide Mounting Instructions

Ultran® Slide Mounting Instructions

Improper mounting of the Ultran® Slide could result in binding and/or excess breakaway. As a rule of thumb, the end blocks should be mounted flat with no more than 0.30° of differential misalignment end-to-end (including both end blocks, i.e., 0.30° on one end block if other end block is square. If both end blocks are out of square, the total between them cannot exceed 0.30° . The x dimension represents how much displacement 0.30° represents using $0.0175"$ per inch per degree of misalignment.)



Model	S in (mm)	x in (mm)
007 (5/16" Bore)	2.000 (50.8)	0.010 (0.25)
01 (7/16" Bore)	2.312 (58.7)	0.012 (0.30)
02 (9/16" Bore)	3.000 (76.2)	0.016 (0.40)
04 (3/4" Bore)	3.375 (85.7)	0.018 (0.46)
06 (7/8" Bore)	3.750 (95.3)	0.020 (0.51)
09 (1-1/16" Bore)	4.250 (108.0)	0.022 (0.56)
12 (1-1/4" Bore)	4.812 (122.2)	0.025 (0.64)
17 (1-1/2" Bore)	6.000 (152.4)	0.031 (0.79)
31 (2" Bore)	8.000 (203.2)	0.042 (1.07)

The information presented is in Bimba's best engineering opinion and should be used for reference only. Recommendations derived should be verified under actual operating conditions. Bimba reserves the right to change specifications without prior notice.

Bimba Manufacturing Company
 Monee, IL 60449-0068
 Telephone: 708.534.8544
 Email: cs@bimba.com
www.bimba.com
 Rev Level: 0

Leaders in Actuation.

To learn more about this product, scan this QR code with your mobile device.

