

# BTP Series Bench Top Press & Cylinders



**Bench Top Press**

**Page 196**

**Press Cylinders**

**Page 199**



**95% OF OUR CYLINDERS SHIP IN 2-3 DAYS!  
ONE DAY RUSH SERVICE AVAILABLE ON ALL CATALOGED CYLINDER MODELS!**

# HEAVY DUTY BENCH TOP PRESS



## MODEL: BTP-501

FOR SINGLE PISTON ROD, 5.00" BORE, MF1 MOUNT CYLINDERS

Heavy Duty Bench Top Press shown with 5.00" Bore (3) Stage Multi-Stage Cylinder and Micro-Adjust precision stroke adjustment

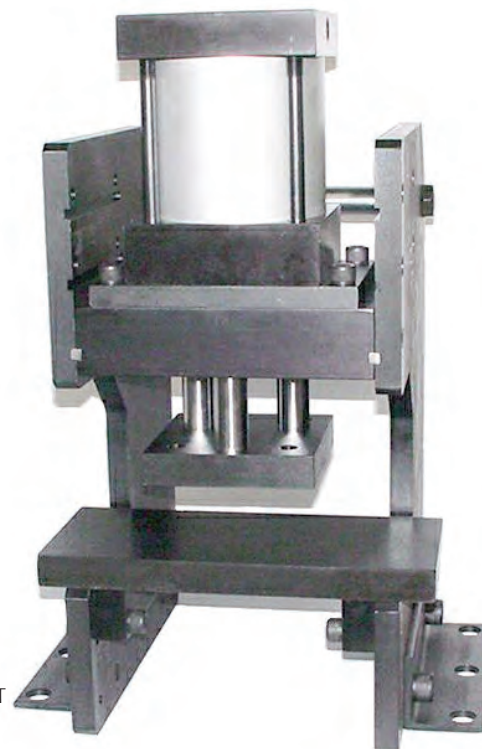

## MODEL: BTP-502

FOR 'TRA' TRIPLE PISTON ROD, 5.00" BORE, MF1 MOUNT CYLINDERS

Heavy Duty Bench Top Press shown with 5.00" Bore Single-Stage Triple Rod Cylinder and Tooling Plate

### Heavy Duty Bench Top Press Features

- Heavy duty STEEL keyed & bolted construction.
- Adjustable work heights - Choose from three different built-in height settings (2" increments).
- Open work area - Allows for through feed or side feed of large parts.
- Removable, oversized ground tool plate, dowel pinned to press frame - Provides precision location of tool plate to press frame.
- Press designed to accept 5.00" Bore NFPA standard cylinders, Multi-Stage cylinders, or optional Triple Rod Cylinders.
- Optional External Mounted Non-Rotating Feature.
- Strokes from 1.00" to 6.00".
- Easy to Assemble or can be ordered fully assembled.
- Finish - All steel parts are Black Oxide Plated, aluminum parts are Anodized.

# HOW TO ORDER: BENCH TOP PRESS

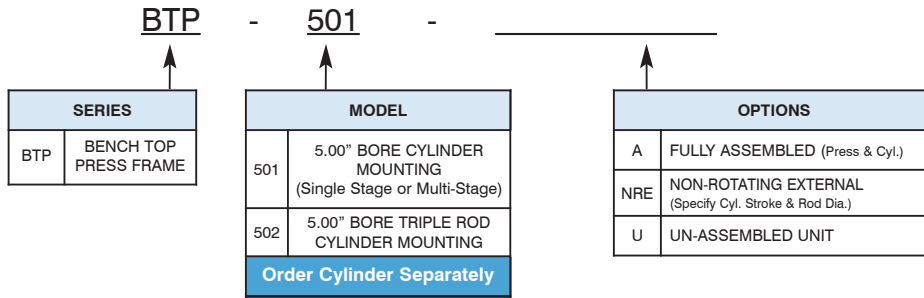

## BENCH TOP PRESS: DIMENSIONS

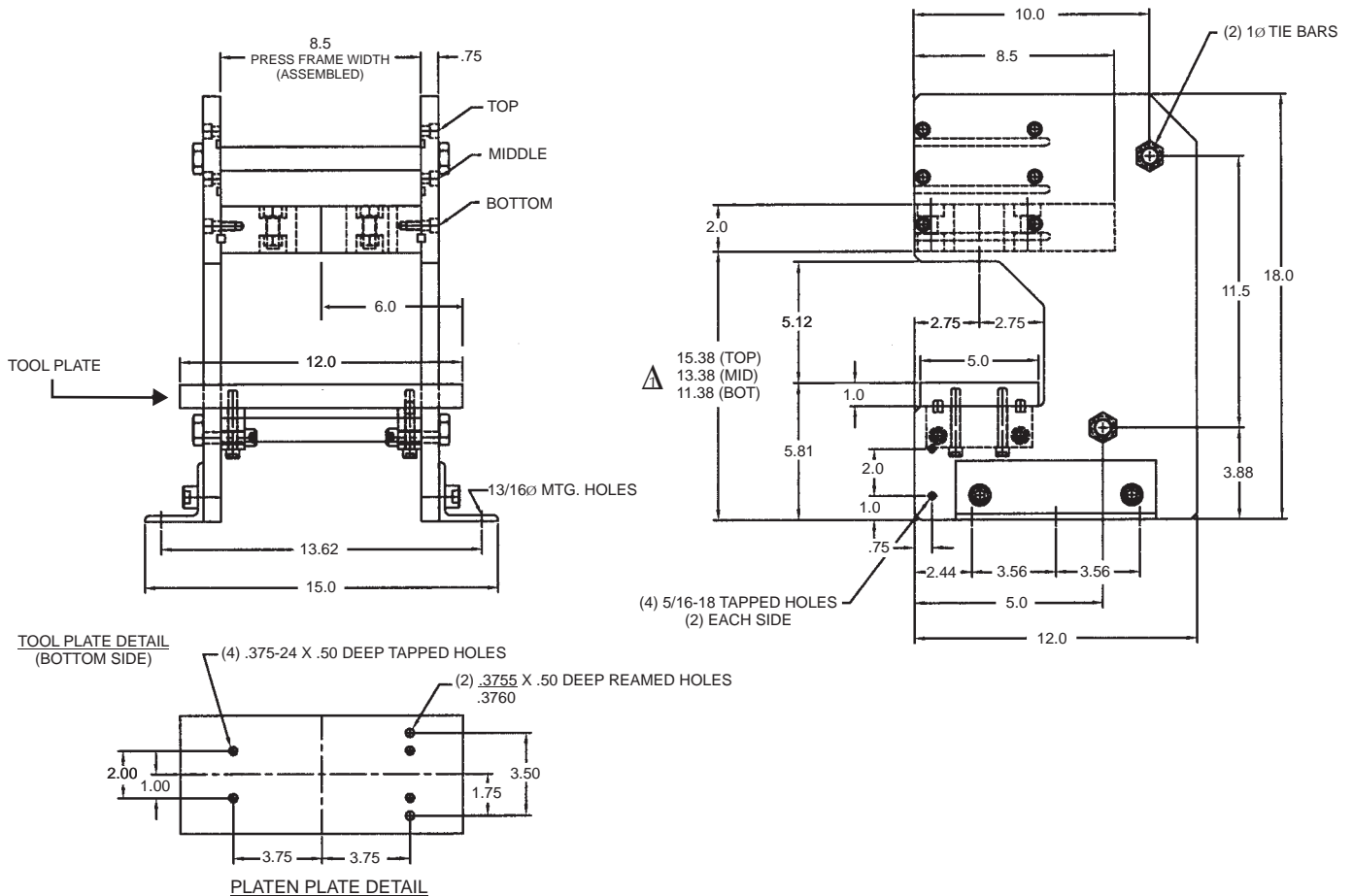

### NOTES:

△ Dimension reflects the press top plate mounted in the bottom (lowest) position. Add 2" for mid position and 4" for top position

- Mounting brackets are reverseable and can be assembled on inside of press frame to reduce overall width.

- Weight: 120 pounds (press frame only)

# BENCH TOP PRESS: TECHNICAL DATA

## CYLINDER SELECTION FORCE CHART

EXTEND FORCE									
CYLINDER	ROD DIA.	EFFECTIVE AREA EXTENDING	60 PSI	70 PSI	80 PSI	90 PSI	100 PSI	110 PSI	125 PSI
SINGLE STAGE	1.000 ROD DIA.	19.635	1178	1374	1570	1767	1963	2160	2454
	1.375 ROD DIA.	19.635	1178	1374	1570	1767	1963	2160	2454
(2) STAGE	1.000 ROD DIA.	38.485	2309	2693	3078	3463	3848	4233	4810
	1.375 ROD DIA.	37.785	2267	2644	3022	3400	3778	4156	4723
(3) STAGE	1.000 ROD DIA.	57.334	3440	4013	4586	5160	5733	6306	7166
	1.375 ROD DIA.	55.935	3356	3915	4474	5034	5593	6153	6992
(4) STAGE	1.000 ROD DIA.	76.184	4571	5332	6094	6856	7618	8380	9523
	1.375 ROD DIA.	74.085	4445	5186	5927	6667	7408	8149	9260
(5) STAGE	1.000 ROD DIA.	95.034	5702	6652	7602	8553	9503	10453	11879
	1.375 ROD DIA.	92.235	5533	6456	7379	8301	9223	10145	11529

RETRACT FORCE									
CYLINDER	ROD DIA.	EFFECTIVE AREA EXTENDING	60 PSI	70 PSI	80 PSI	90 PSI	100 PSI	110 PSI	125 PSI
SINGLE STAGE (OR MULTI-STAGE)	1.000 ROD DIA.	18.85	1131	1319	1508	1696	1885	2073	2356
	1.375 ROD DIA.	18.15	1089	1270	1452	1633	1815	1996	2268
TRIPLE ROD	1.000 ROD DIA.	17.279	1036	1209	1382	1555	1728	1900	2160

## PRESS FRAME DEFLECTION CHARTS

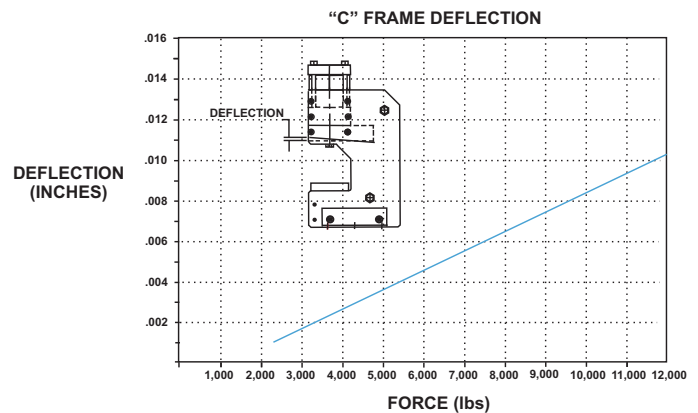
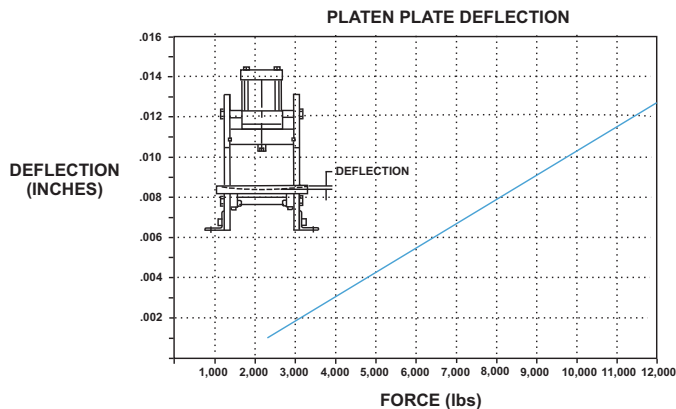

## PRESS FRAME CYLINDER SPEED CHART

### NOTES:

- Cylinder cycle rates can vary depending on air valve sizes, airline diameter and length, type of fitting, and if quick exhaust dumpvalves are used.
- The Speed Chart represents how fast cylinders can cycle and build pressure at each end of stroke (to simulate work being done.) To maximize cylinder performance, all cycle tests were performed using 5 Cv double solenoid valves, .750" air hose, and quick-dump exhaust valves.

CYLINDER	CYCLES PER MINUTE
(1) STAGE-TA	263
(2) STAGE	141
(3) STAGE	125
(4) STAGE	91
(5) STAGE	77

# PRESS FRAME CYLINDER

BTP - How to Order

BTP - Base Dimensions

BTP - Technical Data

Press Frame Cylinders

Press Frame Cyl. Dimensions

Options Page 168

Accessories Page 206

Switches Page 220

Technical Data Page 256

Choose from Single Stage, Multi-Stage, Triple-Rod (Non-Rotating with Tool Plate), or Triple-Rod Multi-Stage Press Cylinders. Double rod end styles are available on all models.

- **SINGLE STAGE:** Basic single bore, double acting cylinder.
- **MULTI-STAGE:** Multi-Stage cylinders are double acting and multiply the output force by supplying air to multiple pistons. The MSEP multiplies the force on the extend stroke and uses only one piston on the return stroke, saving air volume and operating costs. The MSEP/MSRP multiplies the force in both directions. Choose from 2 stage (2S), 3 stage (3S), 4 stage (4S), or 5 stage (5S) models.
- **TRIPLE ROD:** A cylinder with three piston rods and a tooling plate as standard features. The 5.00" square tooling plate distributes the cylinder force over a large work area. Standard features also include (4) .500-20 UNF tapped holes in the tooling plate that can be used to mount customer fixtures or tooling. Triple rod cylinders can be ordered as a single stage, or multi-stage (2S, 3S, 4S or 5S) models.

## About Rod End Styles

Style 3 (KK3) Female Rod End is STANDARD

Other NFPA Styles can be specified (See Chart).

Need a rod end not listed? NO PROBLEM! Each Piston Rod is made to order and does not delay shipment. Coarse (UNC) threads, Metric threads or just plain rod ends are common. Thread lengths are also made to order (Specify: "A"=Length).

NEED SOMETHING NOT LISTED? Just send us a sketch. In most cases, quotes are turned around in one day!

## PISTON ROD END STYLES

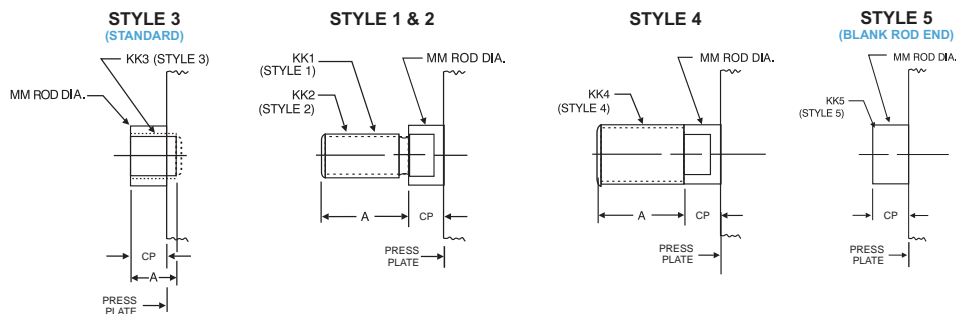

### SINGLE STAGE OR MULTI-STAGE ROD END STYLES & OPTIONS

MM ROD DIAMETER	CP	STANDARD		OPTIONAL						
		STYLE 3 - FEMALE		STYLE 1 - MALE		STYLE 2 - MALE		STYLE 4 - MALE		STYLE 5 - MALE
		KK3	A	KK1	A	KK2	A	KK4	A	KK3
1.000 Standard	0.875	0.750-16	1.125	0.750-16	1.125	0.875-14	1.125	1.000-14	1.125	NO THREAD
1.375 Oversize	0.875	1.000-14	1.625	1.000-14	1.625	1.250-12	1.625	1.375-12	1.625	

## HOW TO ORDER: SINGLE STAGE

**TAP - MX3 - 5 x 1 -**

**SERIES**  
TAP 250 PSI AIR

**NFPA MOUNT**

**BORE**

**STROKE**  
0" to 6" MADE TO ORDER

**STYLE**  
SINGLE ROD (LEAVE BLANK)  
D = DOUBLE ROD END (REQUIRED FOR "MA" OPTION)

**ROD STYLE END & MODIFICATIONS**

KK3	FEMALE ROD THREAD (LEAVE BLANK)
KK3S	STUDDED PISTON ROD (WITH KK3)
KK1	SMALL MALE ROD THREAD
KK2	LARGE MALE ROD THREAD
KK4	FULL DIAMETER MALE ROD THREAD
KK5	BLANK ROD END
"A"	EXTENDED PISTON ROD THREAD (SPECIFY)
"C"	EXTENDED PISTON ROD (SPECIFY)

**OPTIONS**

A / O	AIR / OIL PISTON
B**	.25" URETHANE BUMPER BOTH ENDS
BH**	.25" URETHANE BUMPER HEAD ONLY
BC**	.25" URETHANE BUMPER CAP ONLY
MPR	MAGNETIC PISTON FOR SWITCHES
MS	METALLIC ROD SCRAPER (BRASS)
OP	OPTIONAL PORT LOCATION
OS	OVERSIZED ROD DIAMETER (1.375")
TH	400 PSI HYDRAULIC, NON-SHOCK
VS	VITON® SEALS
XX	SPECIAL VARIATION (SPECIFY)
BSP, SAE PORTS (SPECIFY SIZE)	

**PORT & CUSHION POSITIONS**

**CUSHIONS**

**NON-CUSHION (LEAVE BLANK)**

H = HEAD CUSHION POSITION 1 STANDARD SPECIFY FOR POSITIONS 2, 3 OR 4 (Example = H2)

C = CAP CUSHION POSITION 5 STANDARD SPECIFY FOR POSITIONS 6, 7 OR 8 (Example = C6)

**MICRO-ADJUST**

MA	MICRO-ADJUST
MAB	WITH NOISE DAMPENING BUMPER INSTALLED

\*\* BUMPERS ADD .25" PER END TO CYLINDER LENGTH

# HOW TO ORDER: MULTI-STAGE

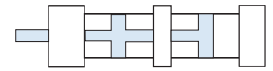

MSEP - MX3 - 5 x 1 x 2S -

<b>SERIES</b>		<b>STYLE</b>		<b>STROKE</b> 0" to 6" MADE TO ORDER	<b>STAGES</b>	<b>ROD STYLE END &amp; MODIFICATIONS</b>		<b>OPTIONS</b>	
MSEP	125 PSI AIR or HYDRAULIC, NON-SHOCK (HIGH FORCE EXTEND)	SINGLE ROD (LEAVE BLANK) D = DOUBLE ROD END (REQUIRED FOR "MA" OPTION)				2S	TWO	KK3	FEMALE ROD THREAD (LEAVE BLANK)
MSEP/MSRP	125 PSI AIR or HYDRAULIC, NON-SHOCK (HIGH FORCE EXTEND AND RETRACT)			3S	THREE	KK3S	STUDDED PISTON ROD (WITH KK3)	BH**	.25" URETHANE BUMPER HEAD ONLY
				4S	FOUR	KK1	SMALL MALE ROD THREAD	BC**	.25" URETHANE BUMPER CAP ONLY
				5S	FIVE	KK2	LARGE MALE ROD THREAD	MPR*	MAGNETIC PISTON FOR SWITCHES
						KK4	FULL DIAMETER MALE ROD THREAD	MS	METALLIC ROD SCRAPER (BRASS)
						KK5	BLANK ROD END	OP	OPTIONAL PORT LOCATION
						"A"	EXTENDED PISTON ROD THREAD (SPECIFY)	OS	OVERSIZED ROD DIAMETER (1.375")
						"C"	EXTENDED PISTON ROD (SPECIFY)	VS	VITON® SEALS
								XX	SPECIAL VARIATION (SPECIFY)
								BSP, SAE PORTS (SPECIFY SIZE)	

<b>CUSHIONS</b>	
<b>NON-CUSHION (LEAVE BLANK)</b>	
H = HEAD CUSHION POSITION 1 STANDARD SPECIFY FOR POSITIONS 2, 3 OR 4 (Example = H2)	
C = CAP CUSHION (MSEP/MSRP ONLY) POSITION 5 STANDARD SPECIFY FOR POSITIONS 6, 7 OR 8 (Example = C6)	

<b>MICRO-ADJUST</b>	
MA	MICRO-ADJUST
MAB	WITH NOISE DAMPENING BUMPER INSTALLED

\*\* BUMPERS ADD .25" PER END TO CYLINDER LENGTH  
\*MPR ADD 0.875" TO CYLINDER LENGTH

## HOW THEY WORK

**Model MSEP**

**4 Stage Shown**

Extension-air supplied to multiple pistons

Retraction-air supplied to one piston

NOTE: Cap cushion not available on MSEP

**Model MSEP/MSRP**

Extension AND Retraction-air supplied to multiple pistons

HEAD AND CAP CUSHION AVAILABLE

To Order, specify: "MSEP/MSRP" (as model number)

Note: Overall lengths are increased

**Model MSE-MSR**

**2 Stage Shown**

## HOW TO ORDER: TRIPLE-ROD (WITH TOOL PLATE)

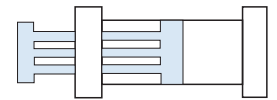

TRAP - MF1 - 5 x 1 x 2S -

<b>SERIES</b>		<b>STYLE</b>		<b>STROKE</b> 0" to 6" MADE TO ORDER	<b>STAGES</b>	<b>CUSHIONS</b>		<b>OPTIONS</b>	
TRAP	SINGLE STAGE, 200 PSI AIR	SINGLE ROD (LEAVE BLANK) D = DOUBLE ROD END (SINGLE ROD AT CAP) (REQUIRED FOR "MA" OPTION)				2S	TWO	<b>NON-CUSHION (LEAVE BLANK)</b>	
TRAP-MSE	MULTI-STAGE EXTEND, 125 PSI AIR			3S	THREE	H = HEAD CUSHION POSITION 2 STANDARD SPECIFY FOR POSITIONS 1 OR 4 (Example = H2)		BH**	.25" URETHANE BUMPER HEAD ONLY
				4S	FOUR	C = CAP CUSHION (TRP ONLY) POSITION 6 STANDARD SPECIFY FOR POSITIONS 5 OR 8 (Example = C6)		BC**	.25" URETHANE BUMPER CAP ONLY
				5S	FIVE			MPR	MAGNETIC PISTON FOR SWITCHES
								OP	OPTIONAL PORT LOCATION
								TH	400 PSI HYDRAULIC, NON-SHOCK
								VS	VITON® SEALS
								XX	SPECIAL VARIATION (SPECIFY)
								BSP, SAE PORTS (SPECIFY SIZE)	

<b>MICRO-ADJUST</b>	
MA	MICRO-ADJUST
MAB	WITH NOISE DAMPENING BUMPER INSTALLED

\*\* BUMPERS ADD .25" PER END TO CYLINDER LENGTH

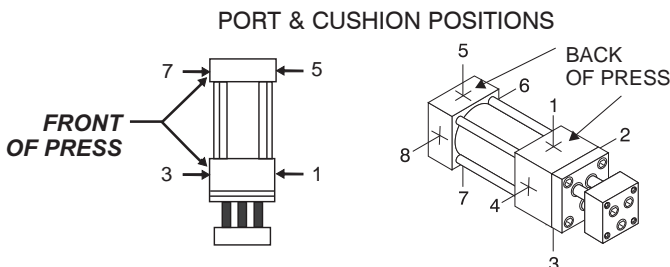

# PRESS FRAME CYLINDER: OPTIONS

## NRE External Non-Rotating

The External Non-Rotating option prevents the piston rod (and any attached tooling) from rotating as the cylinder cycles.

Since the "NRE" bracket and guide rod are externally mounted, they can be added or removed for different applications. All press frames are made to accept this "add on" option.

For high torsional load applications, cylinder can be equipped with a twin guide rod internally ("NR" cylinder option.)

Consult factory for details.

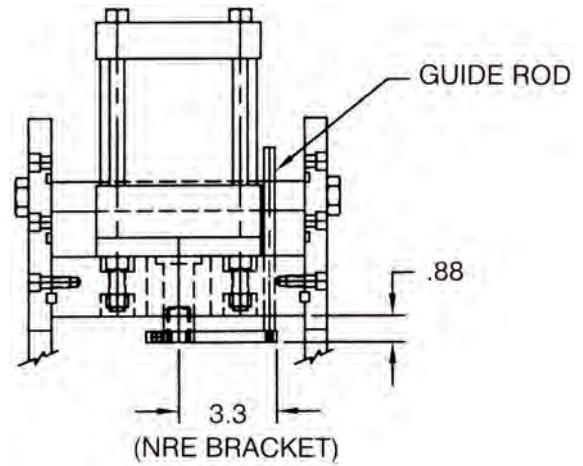

## MA Micro-Adjust

- Allows precision adjustment of cylinder extend stroke
- Easy to read precision scale (.001" calibration)
- Enclosed, no "pinch point" design
- Available on all cylinder models with "D" Double Rod End option
- Up to 6" stroke and adjustment over full range of stroke

Refer to page 175 for more details

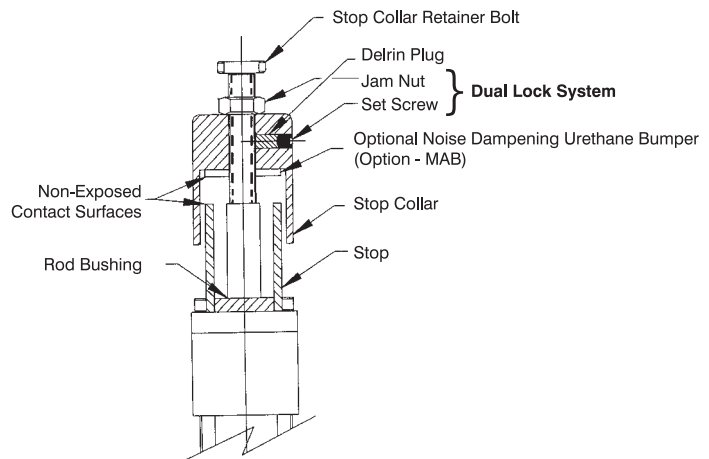

## BALLUFF TRANSDUCER

Balluff transducers can provide positive verification on the depth of each cylinder stroke cycle. This is very important for today's quality control system requirements.

### Ideal Applications:

- Pressing bearings into housings and depth control is critical.
- Parts assembly
- Parts positioning for joining operations (i.e. riveting)

Refer to page 231 for more details

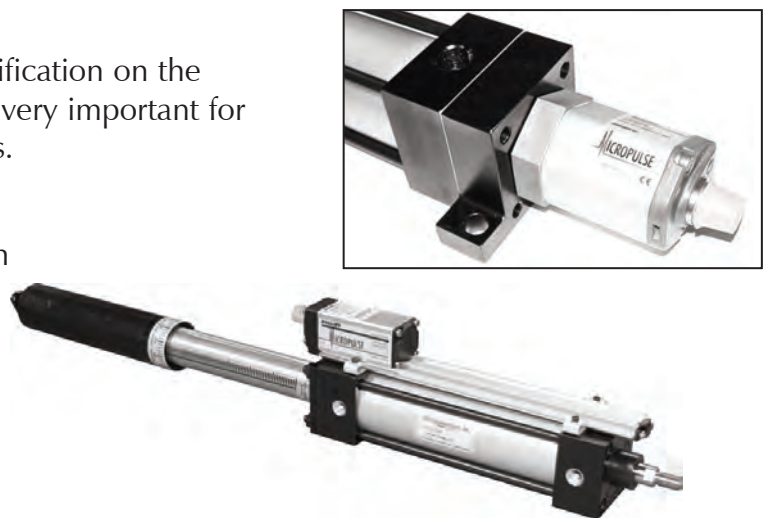

# PRESS FRAME CYLINDER: DIMENSIONS

## TAP (SINGLE STAGE): DIMENSIONS

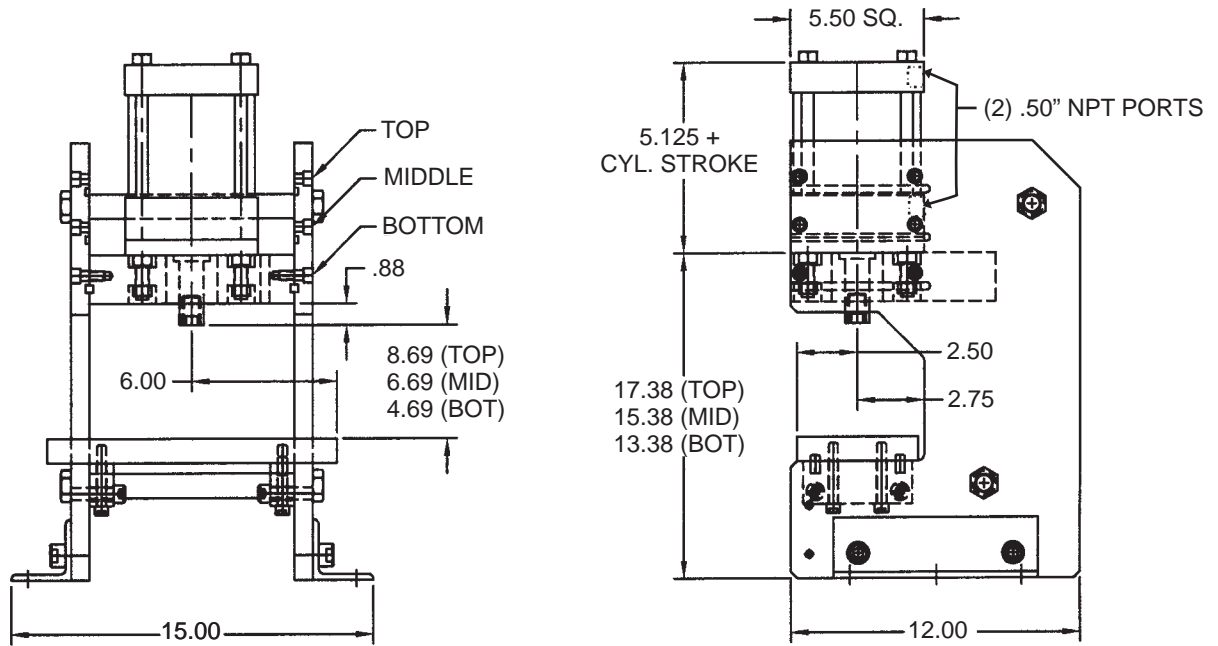

## MSEP 2S (2 STAGE): DIMENSIONS

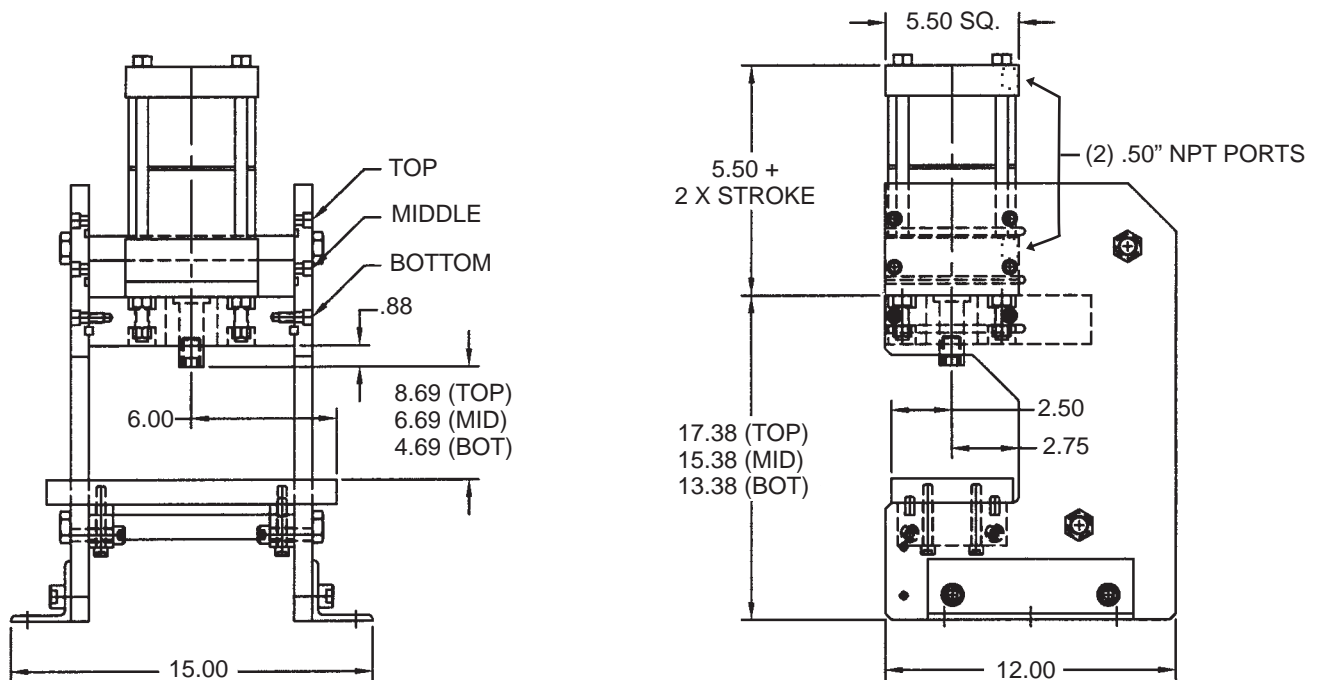

# PRESS FRAME CYLINDER: DIMENSIONS

## MSEP 3S (3 STAGE): DIMENSIONS

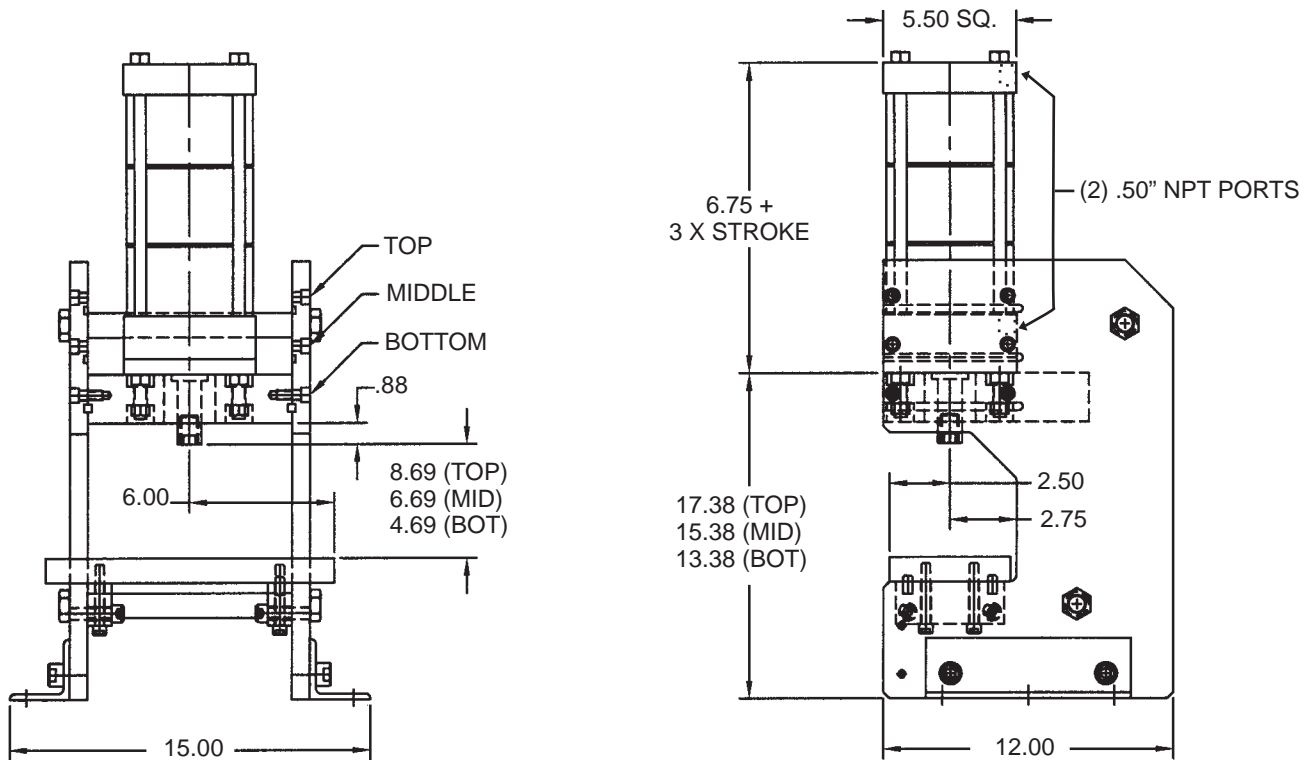

## MSEP 4S (4 STAGE): DIMENSIONS

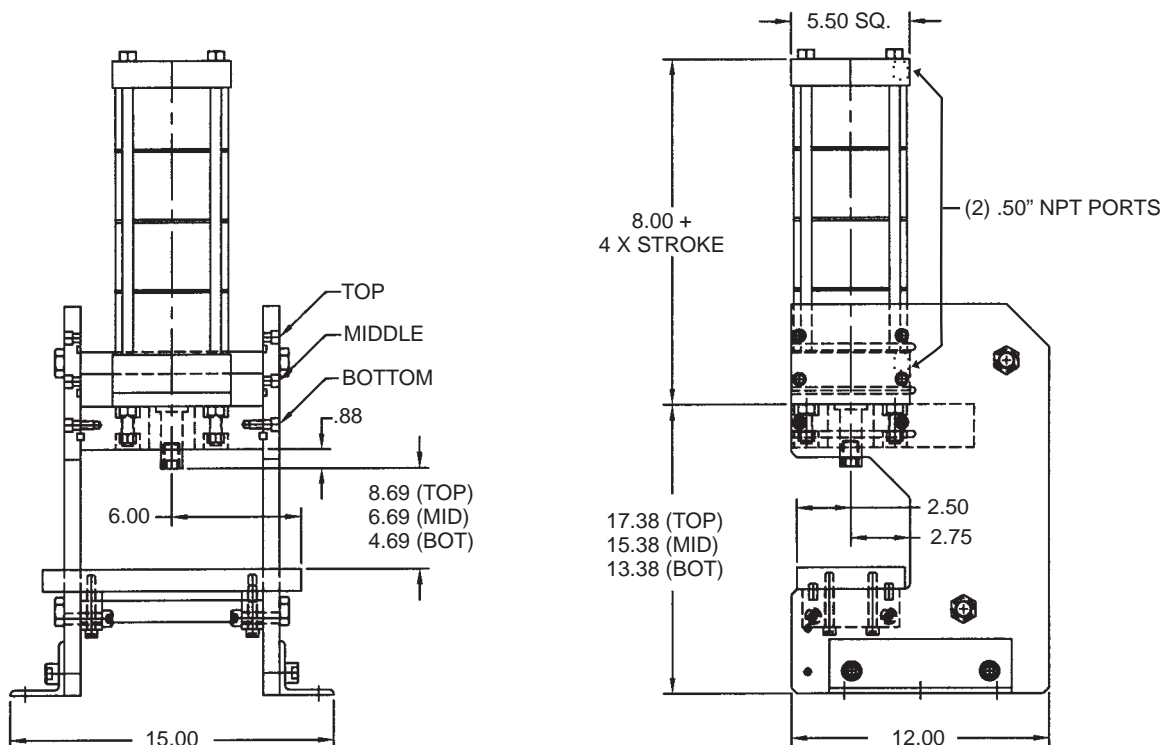

# PRESS FRAME CYLINDER: DIMENSIONS

## MSEP 5S (5 STAGE): DIMENSIONS

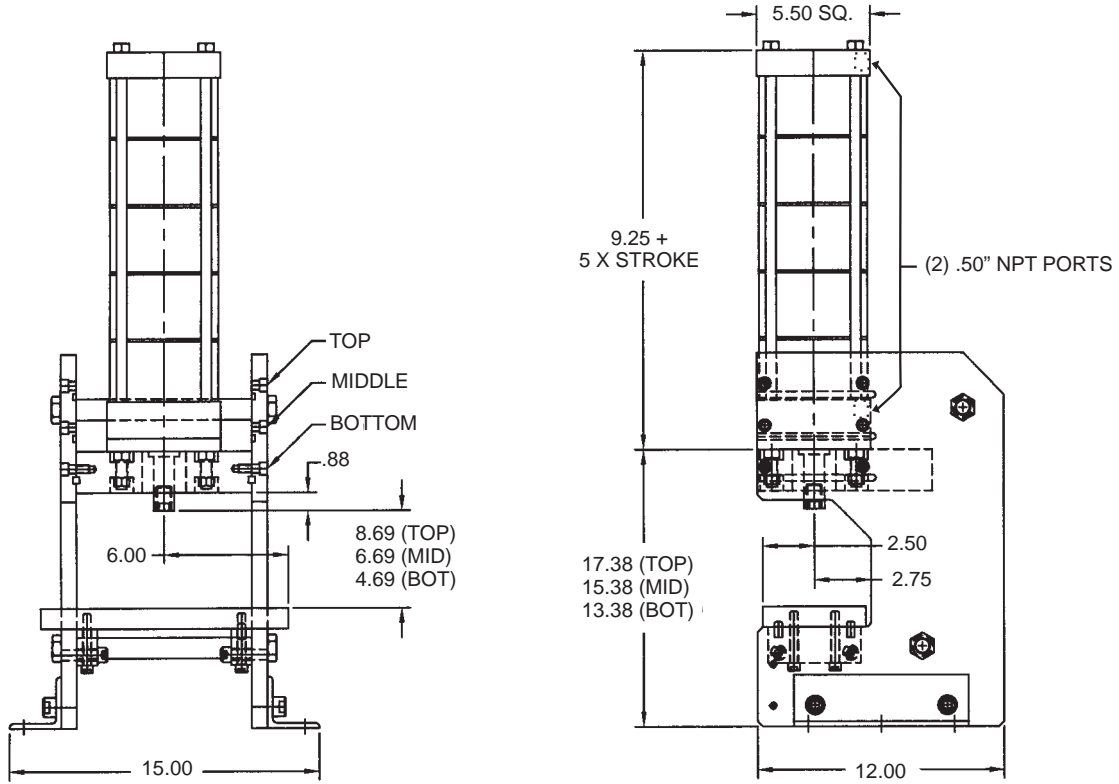

## TRP (TRIPLE ROD): DIMENSIONS

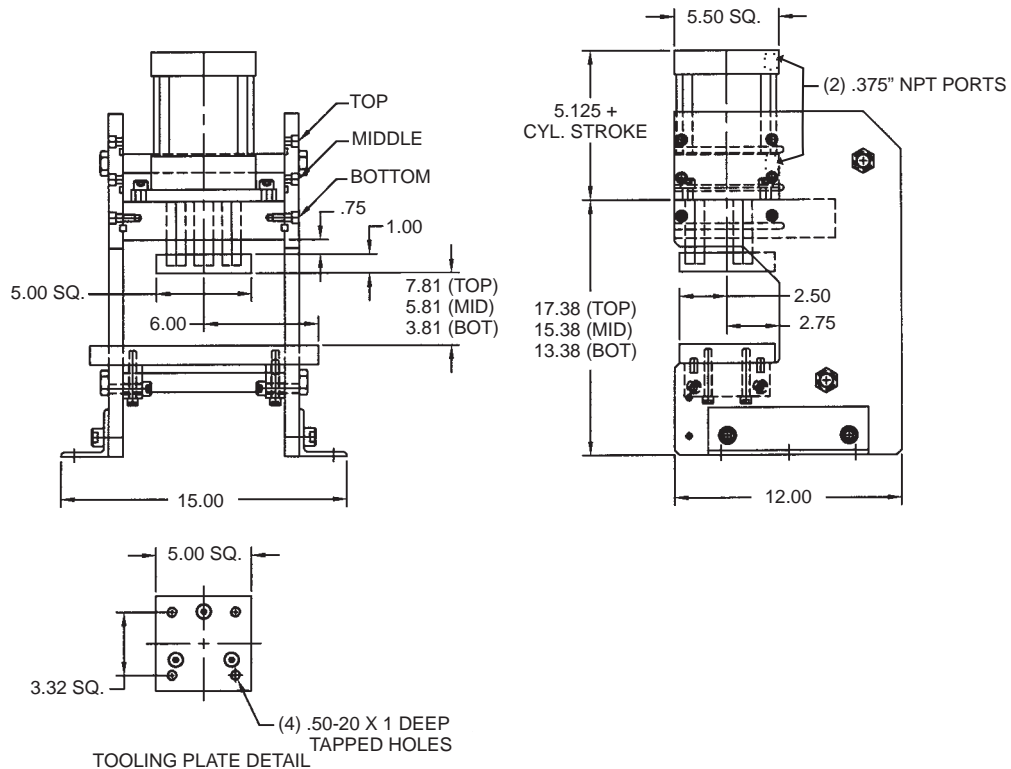

BTP - How to Order

BTP - Base Dimensions

BTP - Technical Data

Press Frame Cylinders

Press Frame Cyl. Dimensions

Options Page 168

Accessories Page 206

Switches Page 220

Technical Data Page 256